

**W1** FB: 94032,00  
 Temp B: 18,00  
 Cond. B: 0,19  
 COD B: 4,00  
 TSS B: 5,00

**W2** FB: 91926,00  
 Temp B: 16,00  
 Cond. B: 0,19  
 COD B: 4,00  
 TSS B: 5,00

**W3** FB: 71998,00  
 Temp B: 18,00  
 Cond. B: 0,19  
 COD B: 4,00  
 TSS B: 0,00

**W4** FB: 38940,00  
 Temp B: 50,00  
 Cond. B: 0,19  
 COD B: 10,00  
 TSS B: 0,00

**D1** FB: 85596,00  
 Temp B: 34,25  
 Cond. B: 1,17  
 COD B: 1116,58  
 TSS B: 24,99

Slightly different from measured values

Company I06: Initial - overview

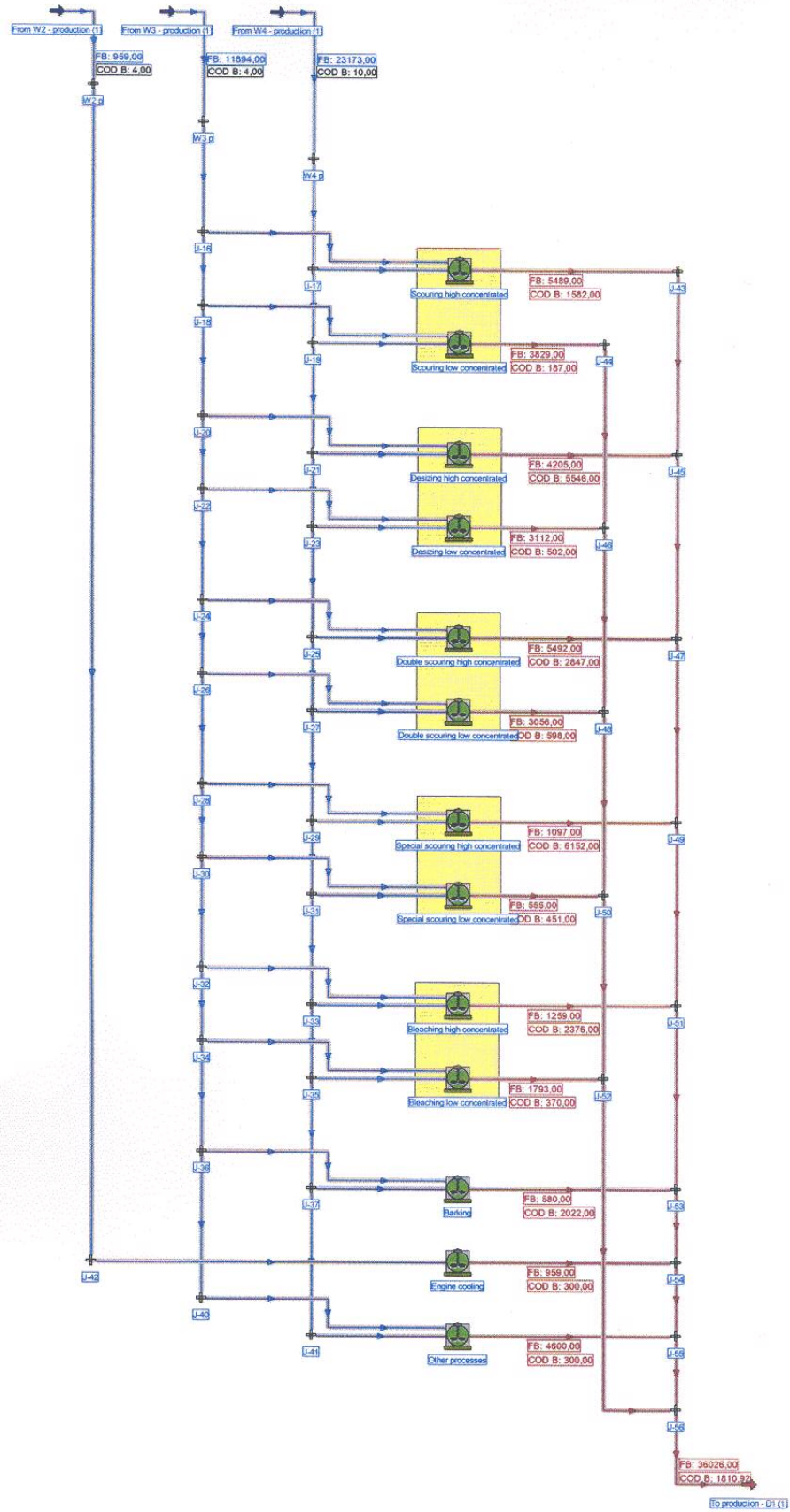

Company I06: Initial - pretreatment

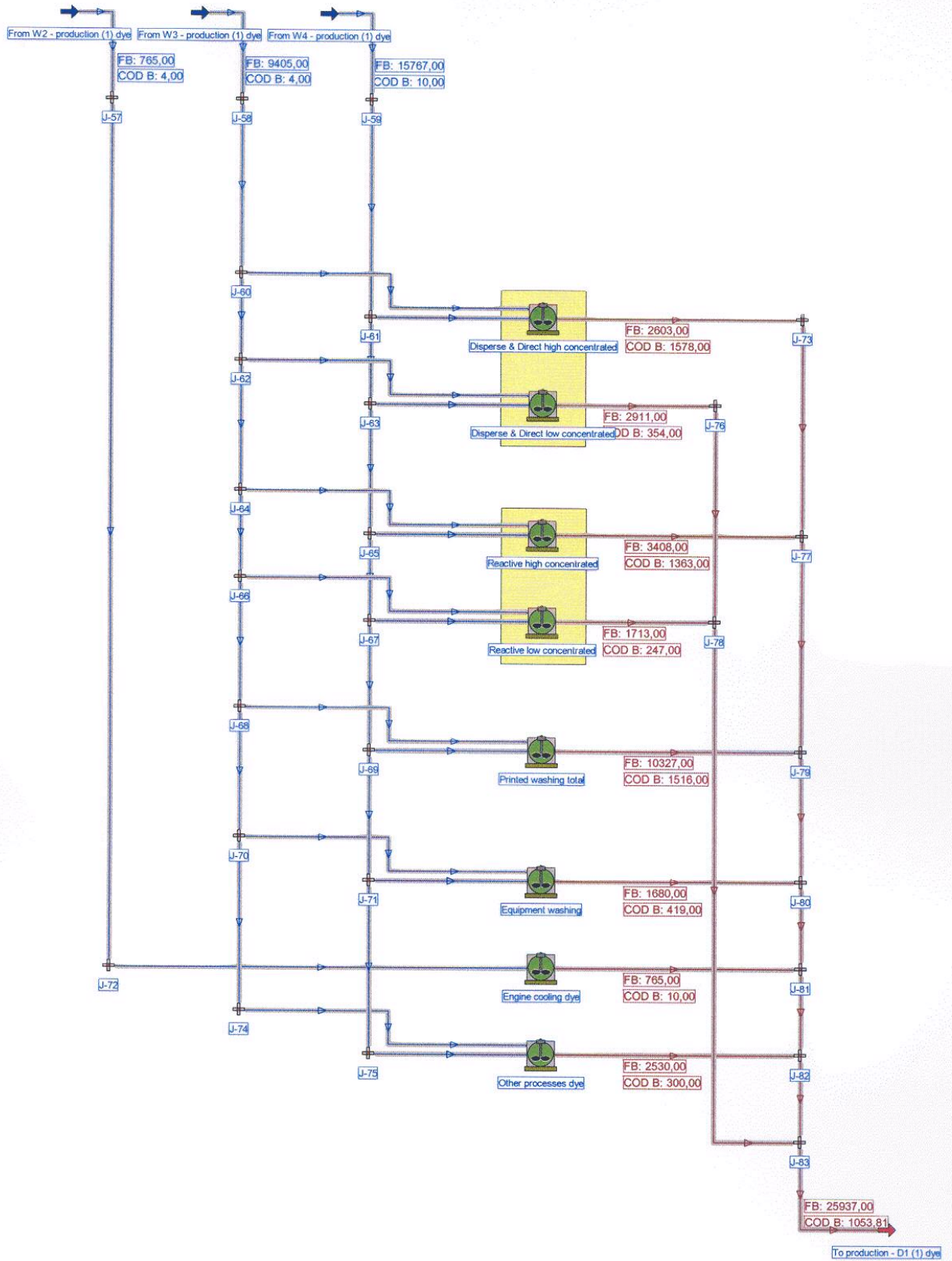

Company I06: Initial - dyeing

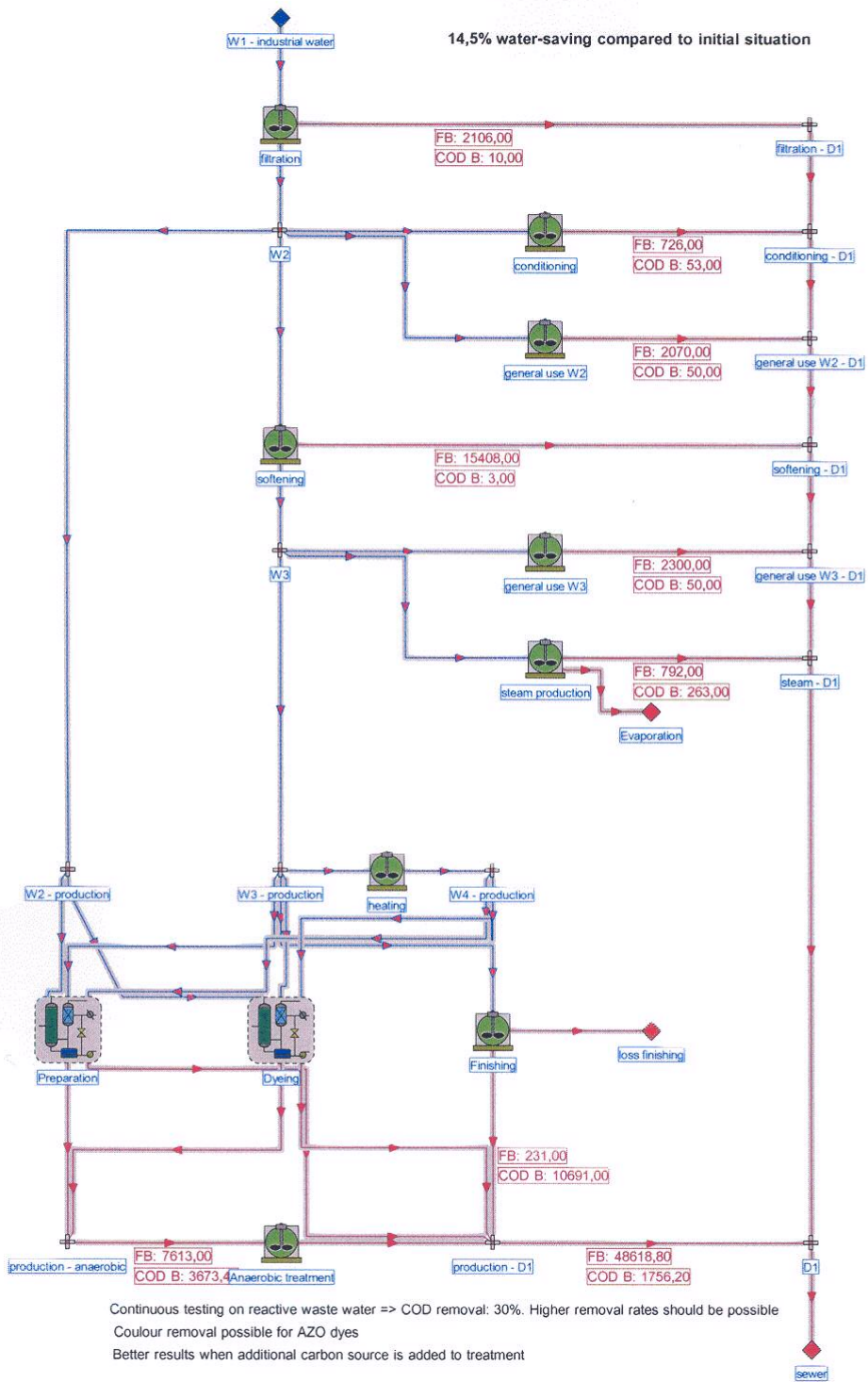

**W1**  
 FB: 80456,80  
 Temp B: 18,00  
 Cond. B: 0,19  
 COD B: 4,00  
 TSS B: 5,00

**W2**  
 FB: 78350,80  
 Temp B: 16,00  
 Cond. B: 0,19  
 COD B: 4,00  
 TSS B: 5,00

**W3**  
 FB: 58422,80  
 Temp B: 18,00  
 Cond. B: 0,19  
 COD B: 4,00  
 TSS B: 0,00

**W4**  
 FB: 38940,00  
 Temp B: 50,00  
 Cond. B: 0,19  
 COD B: 10,00  
 TSS B: 0,00

**D1**  
 FB: 72020,80  
 Temp B: 34,55  
 Cond. B: 1,37  
 COD B: 1192,95  
 TSS B: 44,14

Continuous testing on reactive waste water => COD removal: 30%. Higher removal rates should be possible  
 Colour removal possible for AZO dyes  
 Better results when additional carbon source is added to treatment

Company I06: Optimized - overview



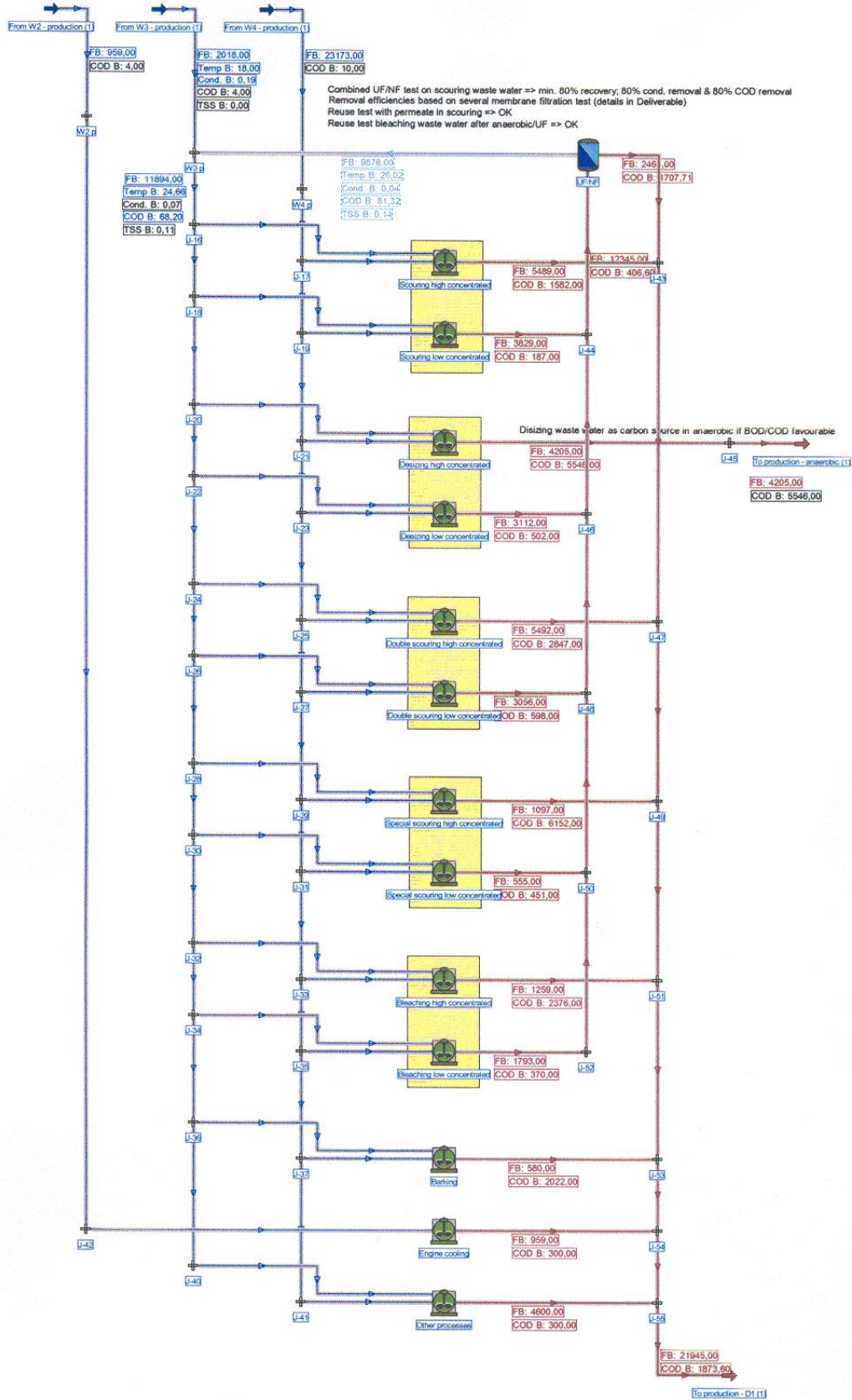

Company I06: Optimized - pretreatment

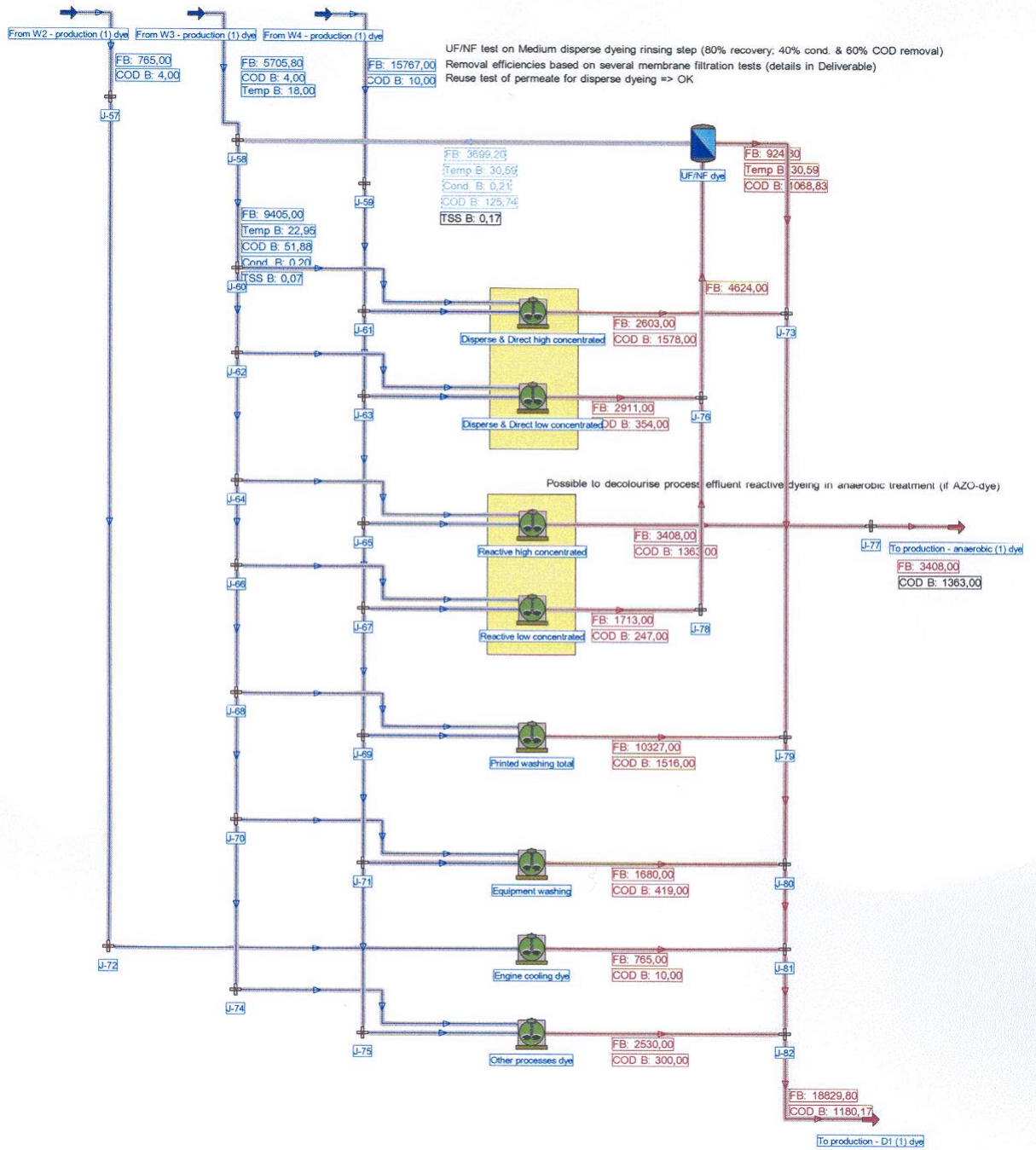

Company I06: Optimized - dyeing

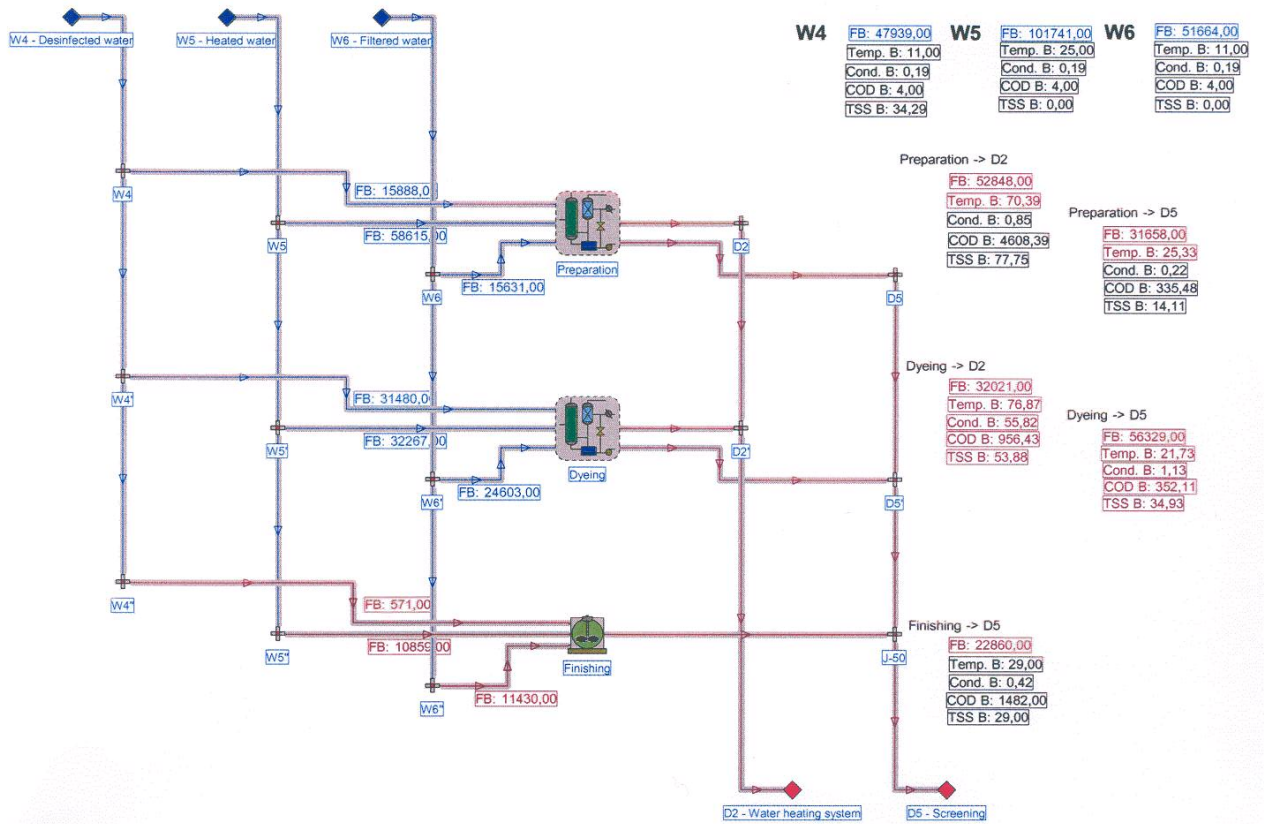

Company I09: Initial - overview

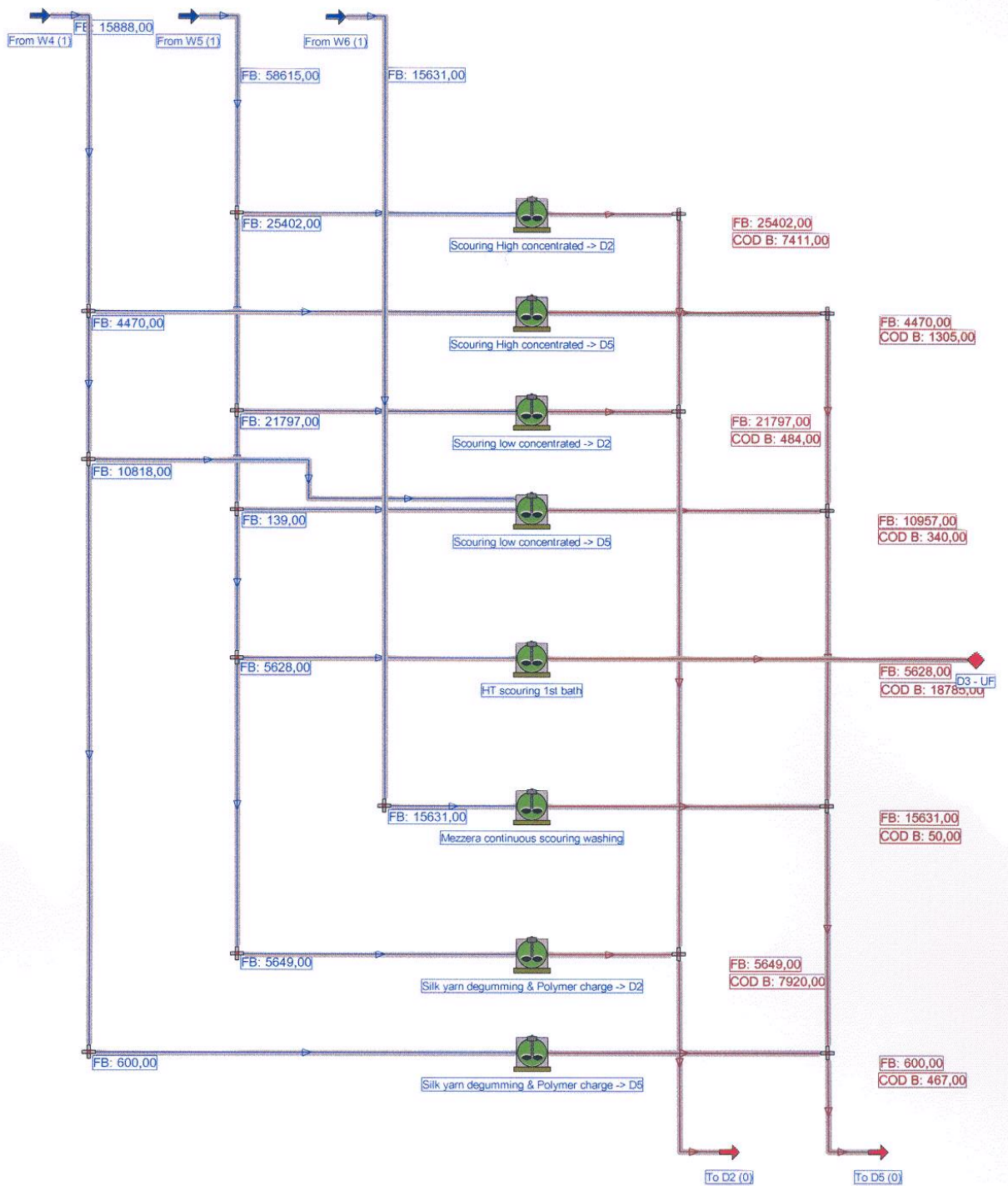

Company I09: Initial - pretreatment



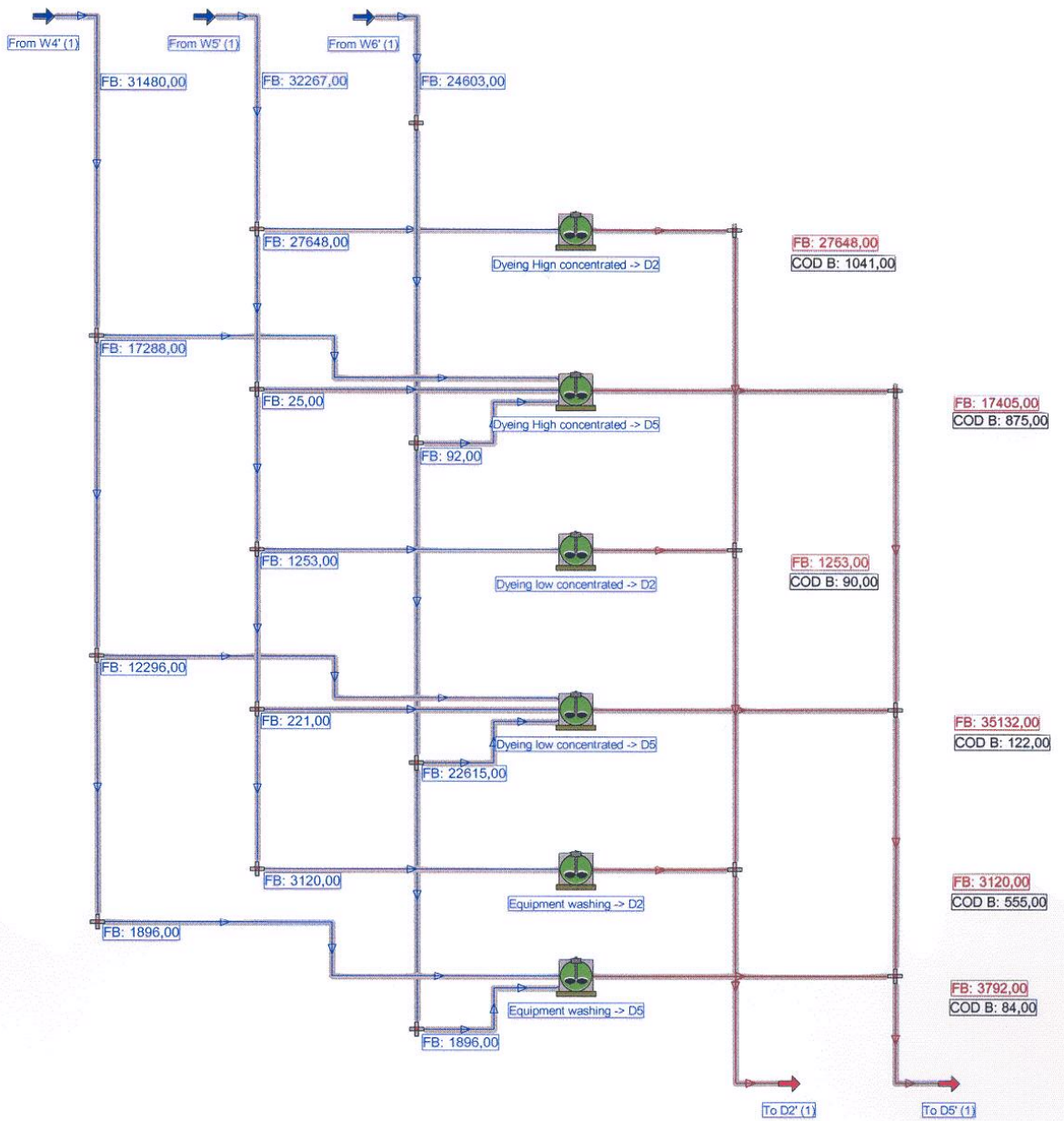

Company I09: Initial - dyeing

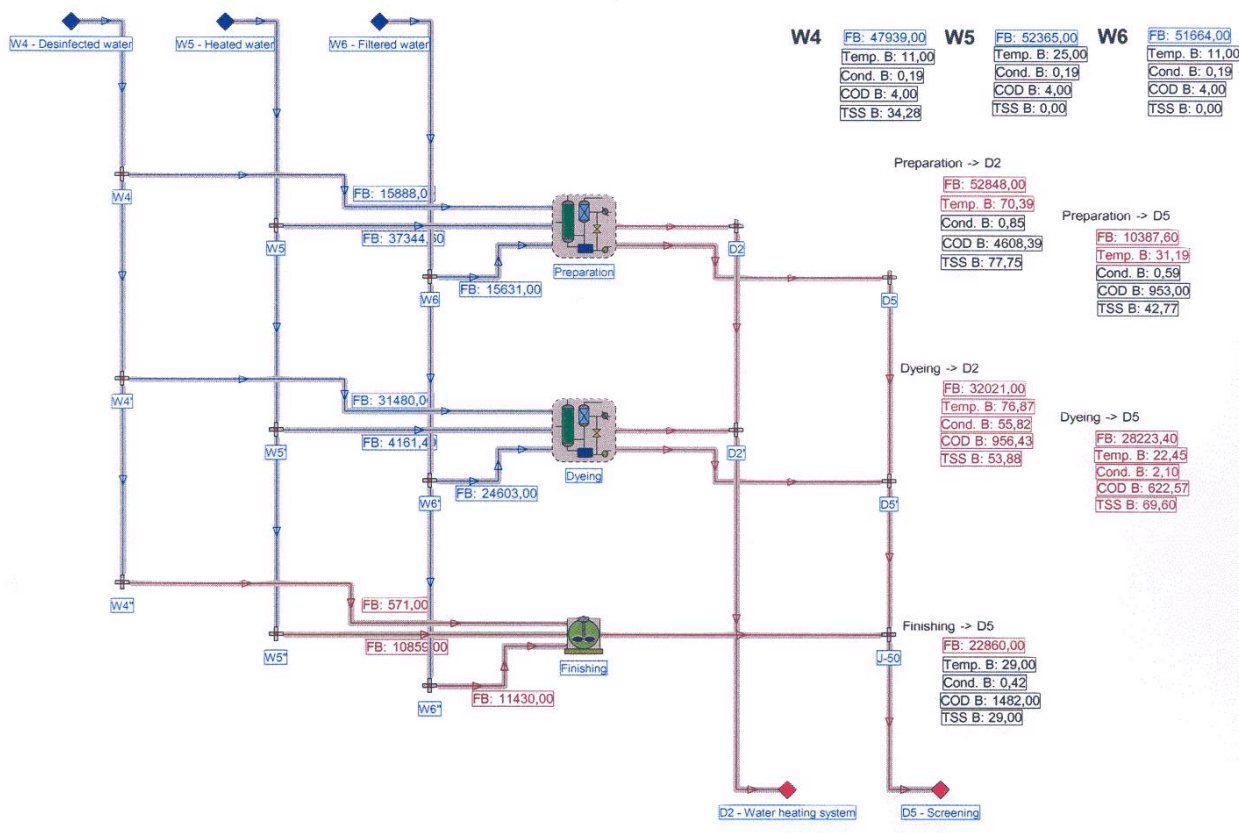

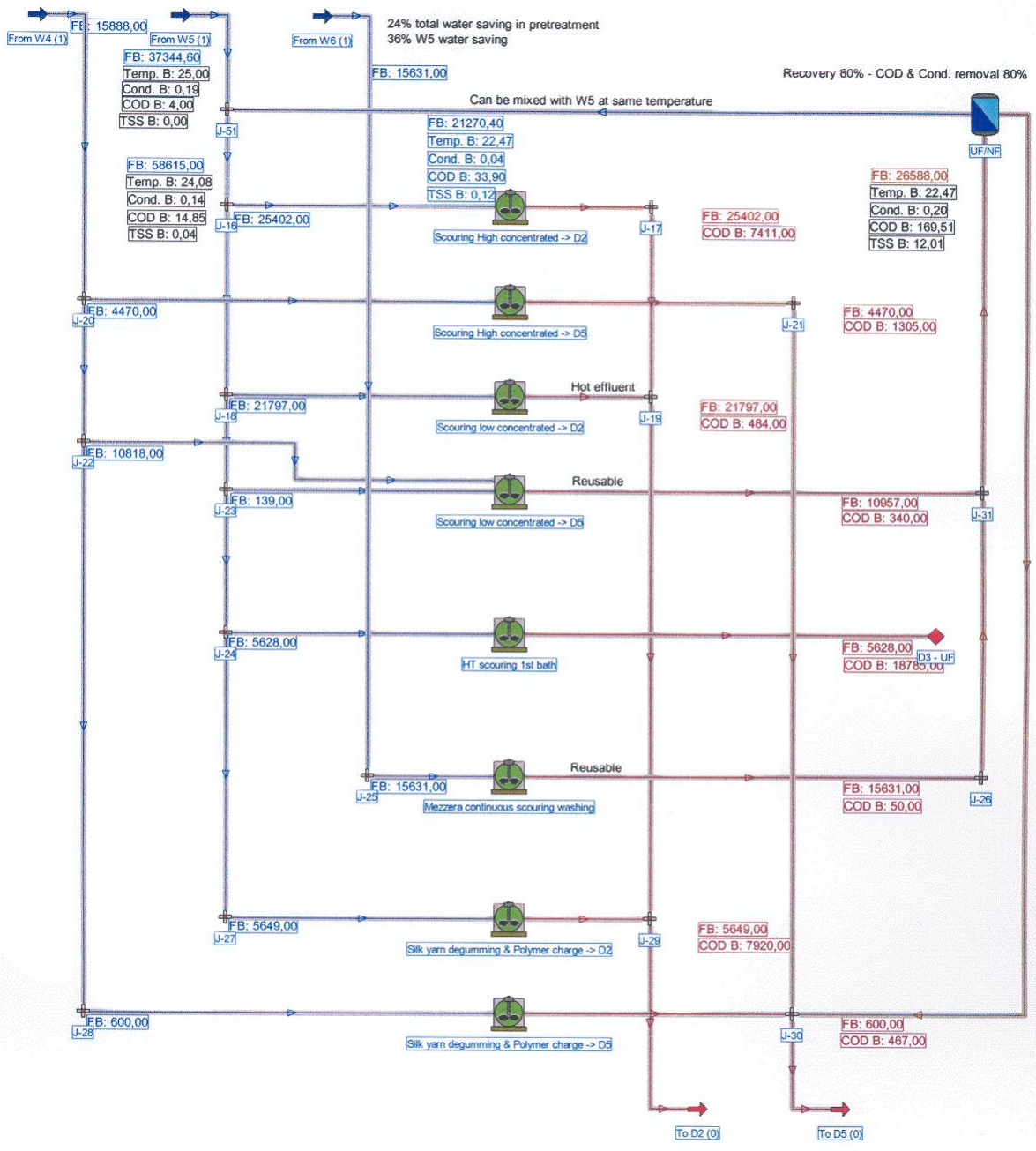

Company I09: Optimized - pretreatment

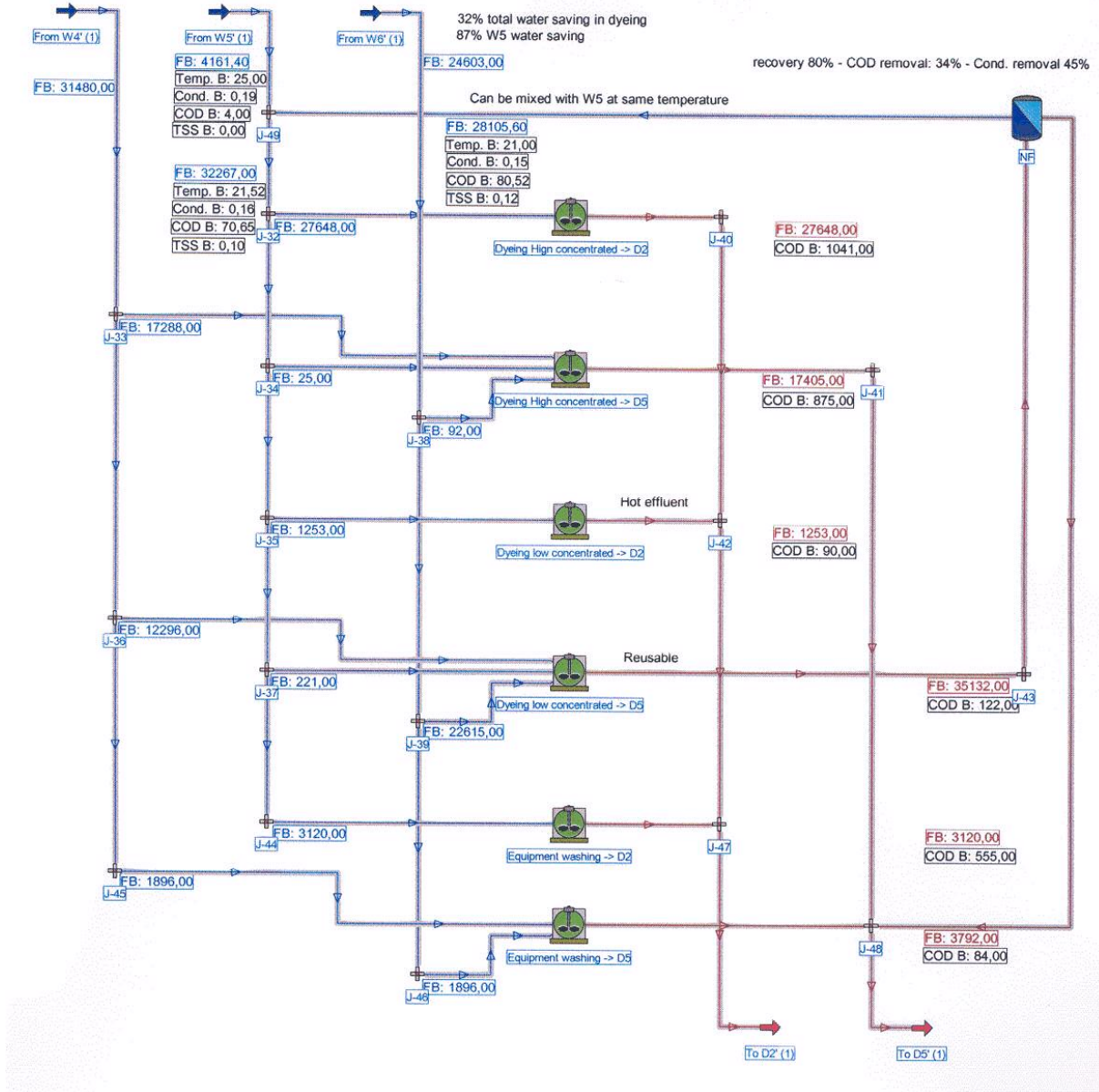

Company I09: Optimized - dyeing



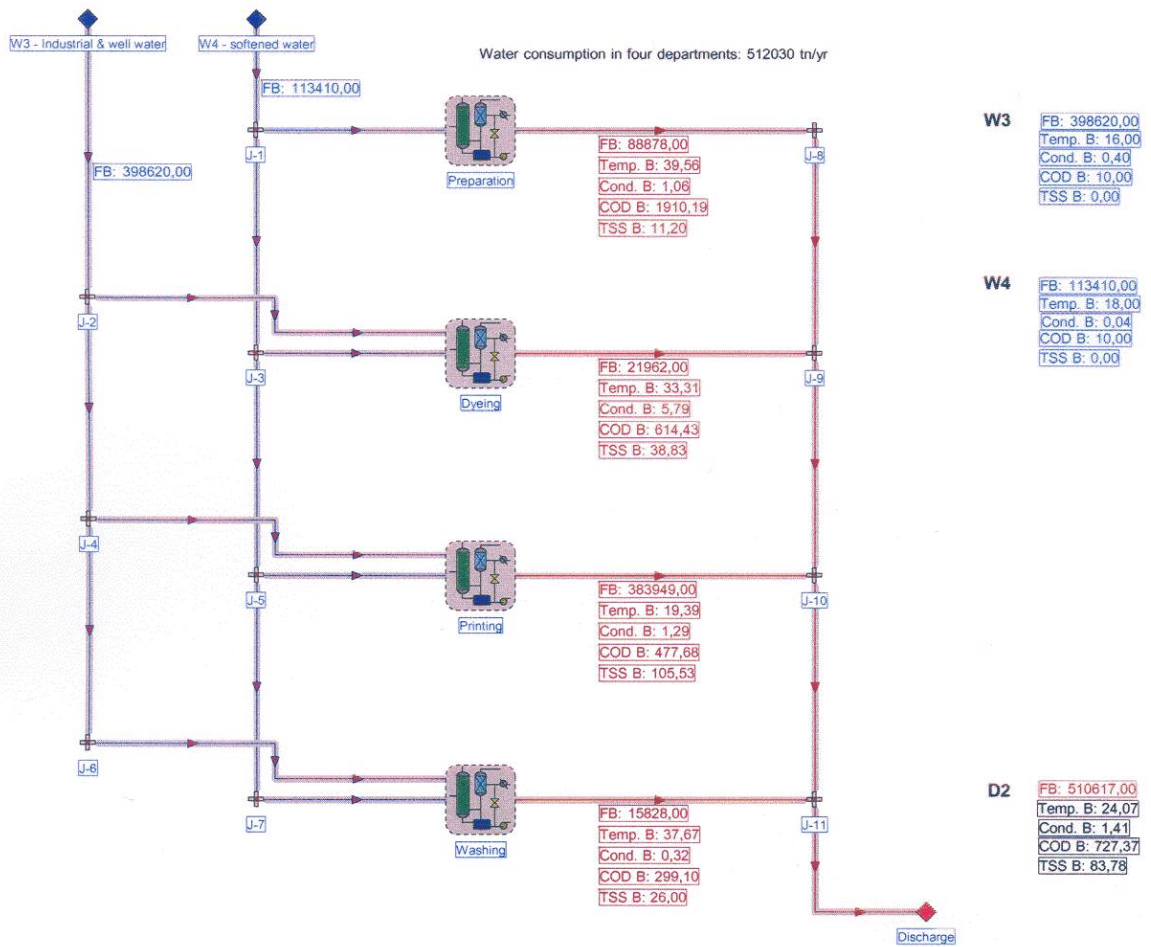

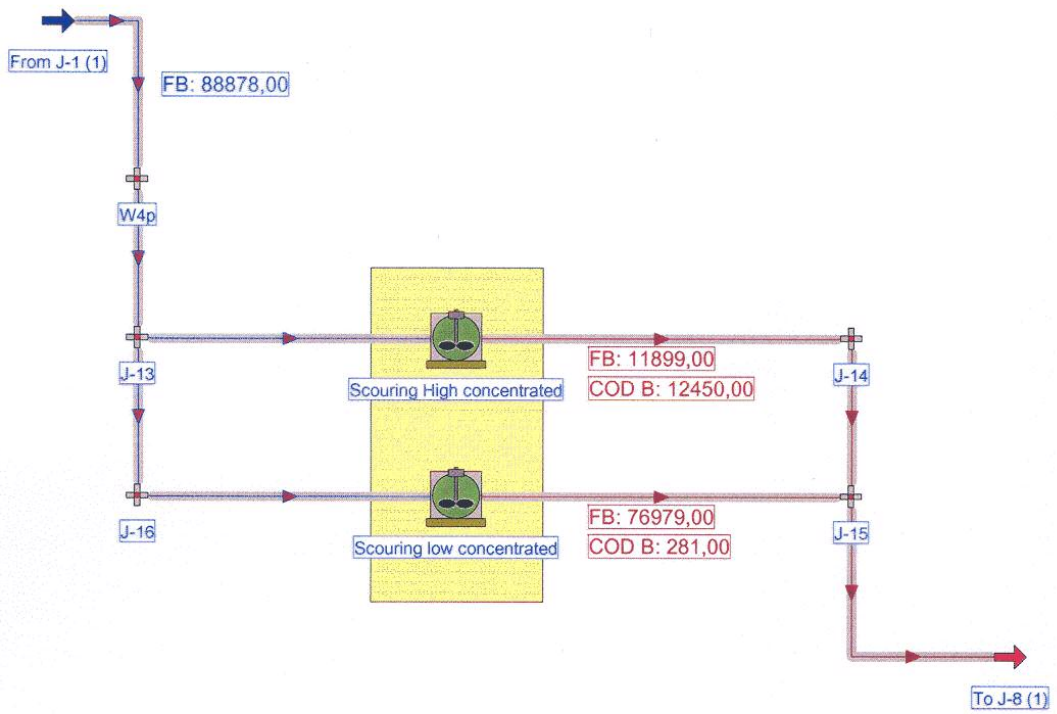

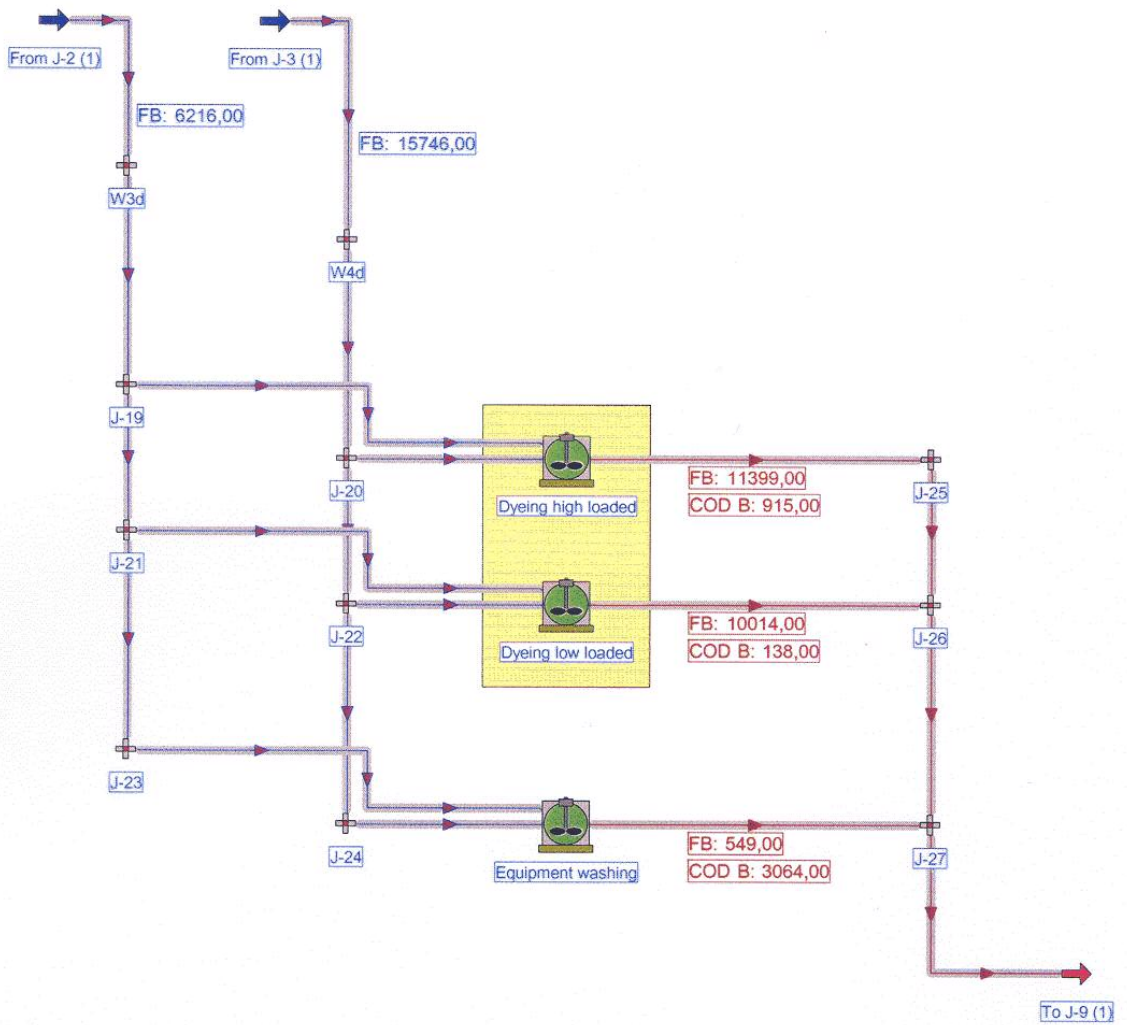

Company I15: Initial - dyeing

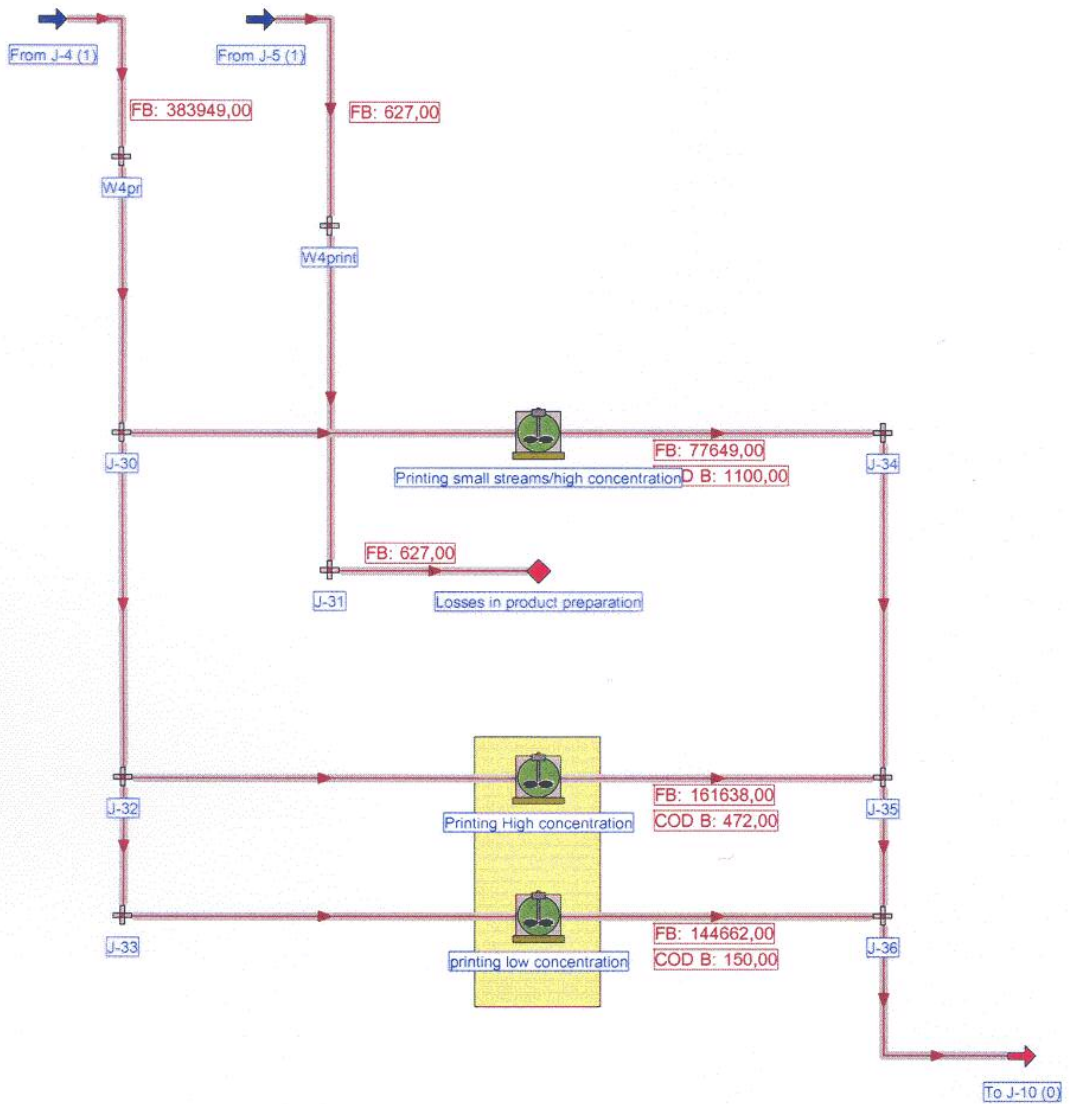



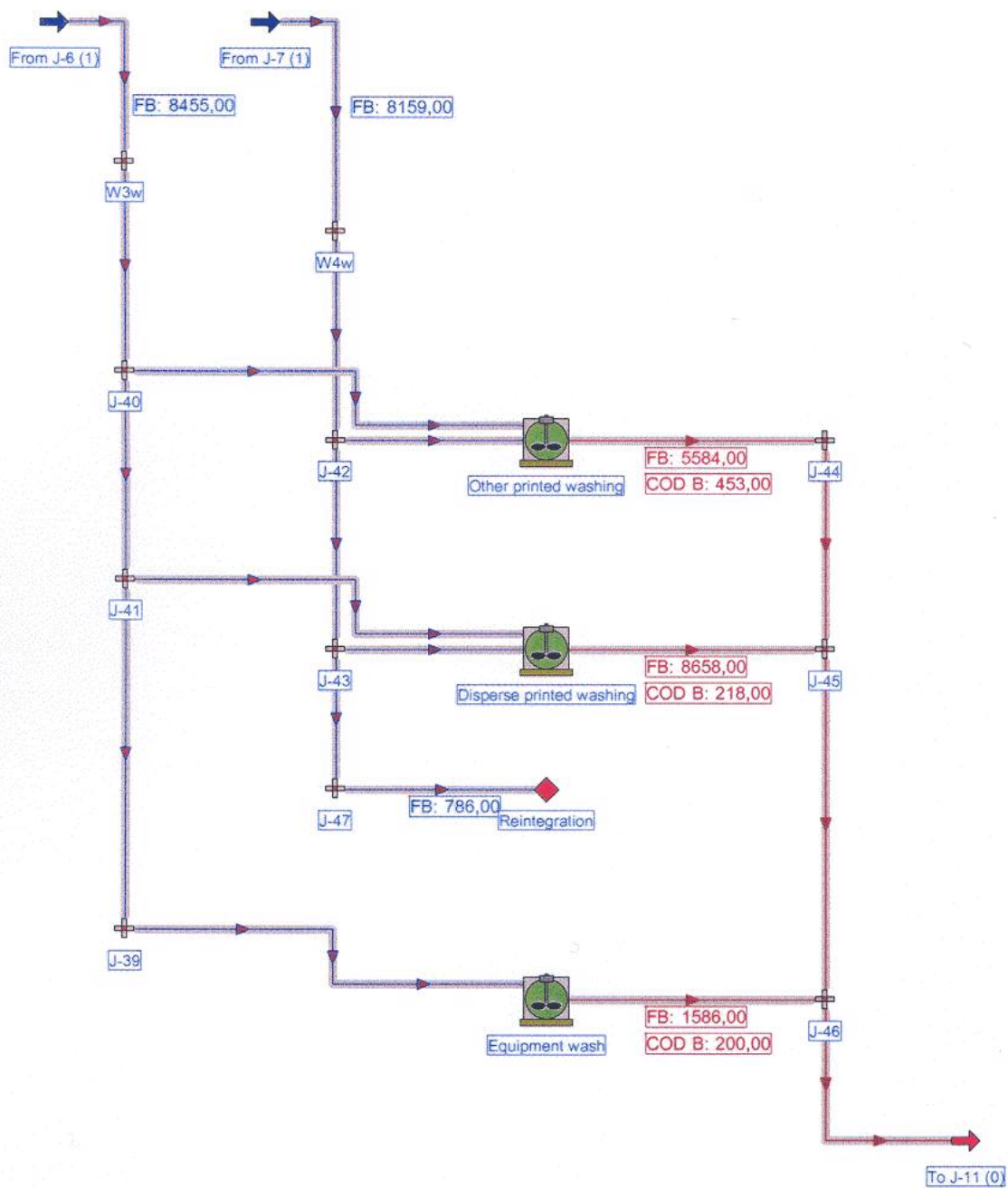

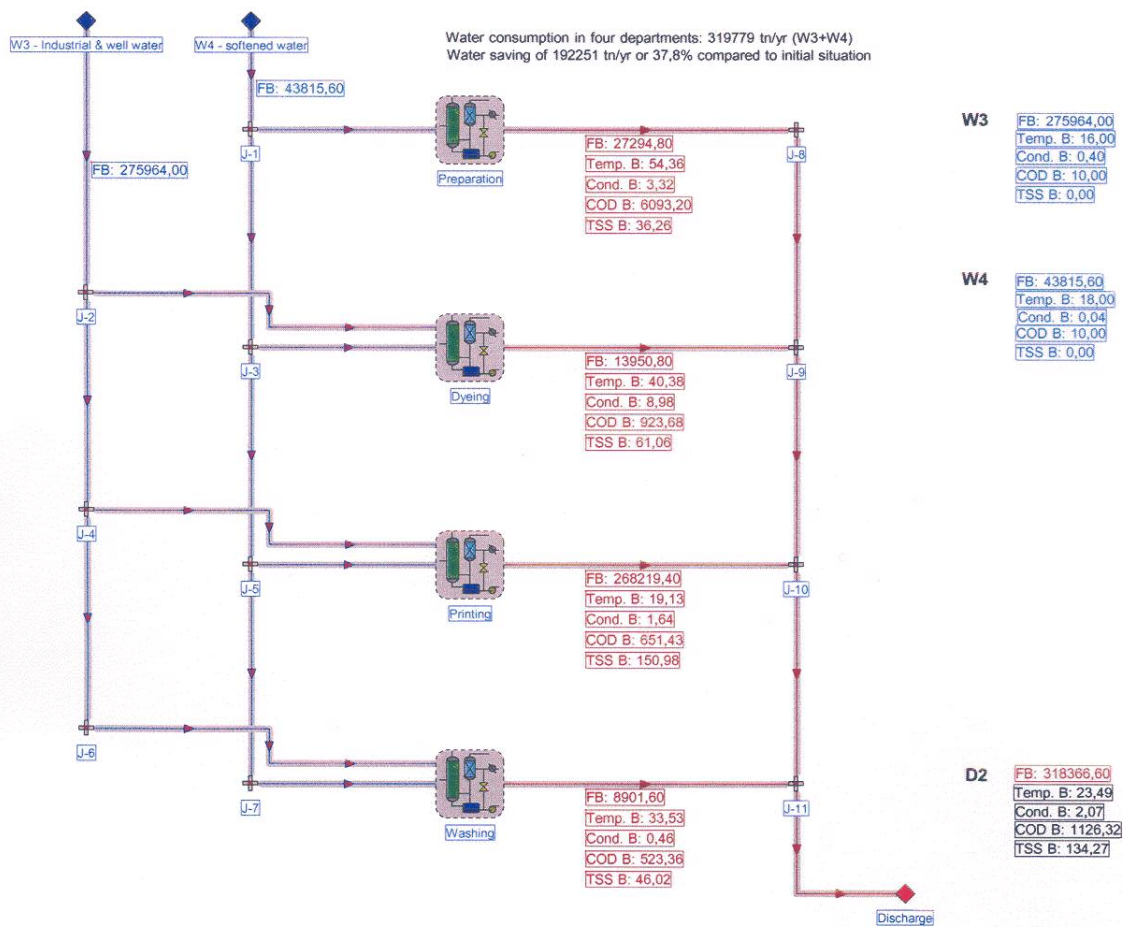

Company I15: Optimized - overview

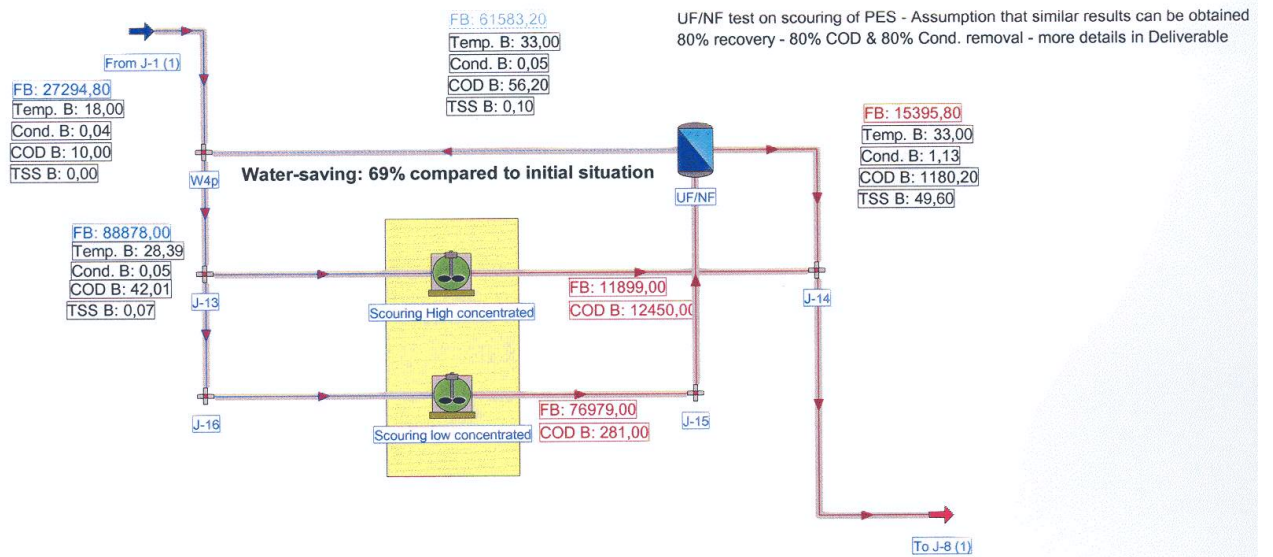

Company I15: Optimized - pretreatment

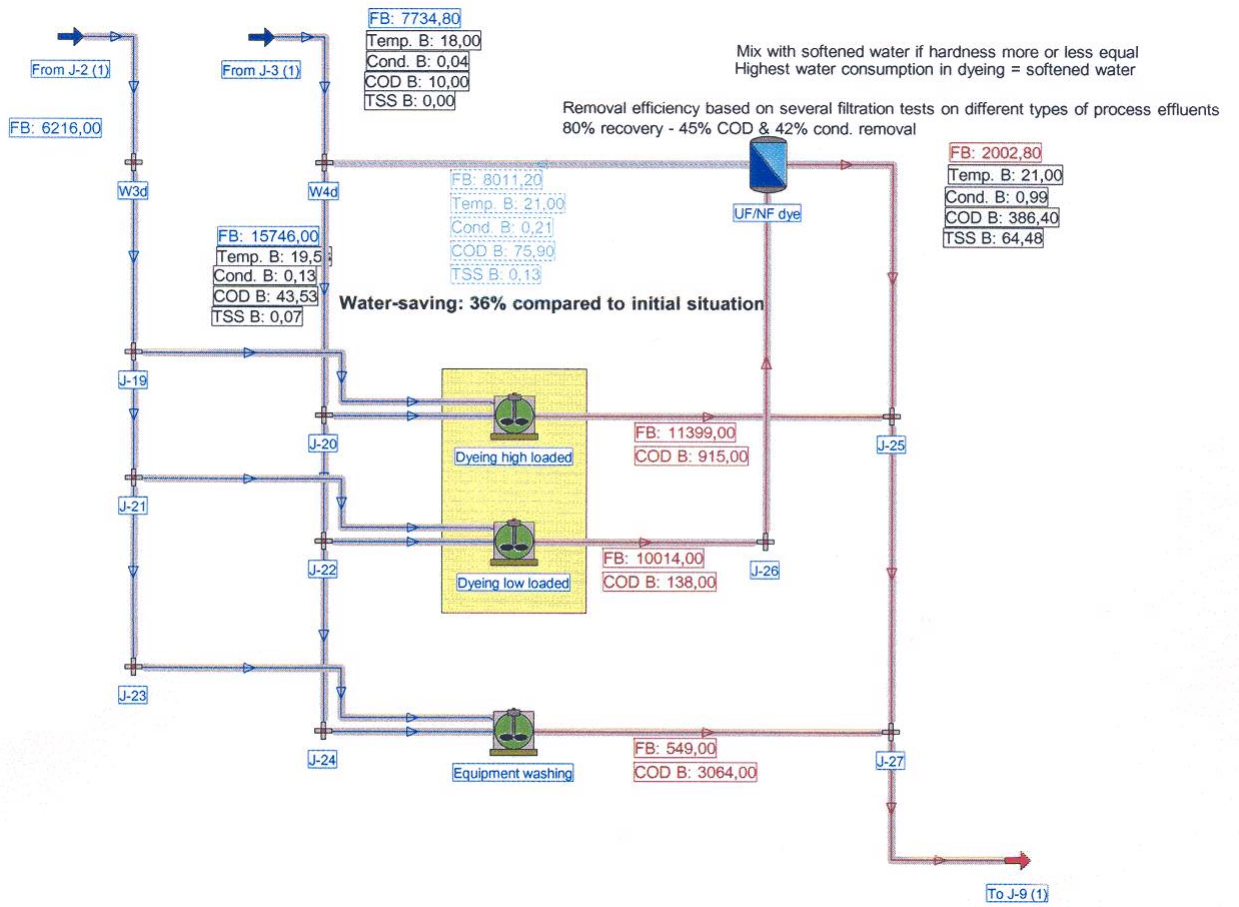



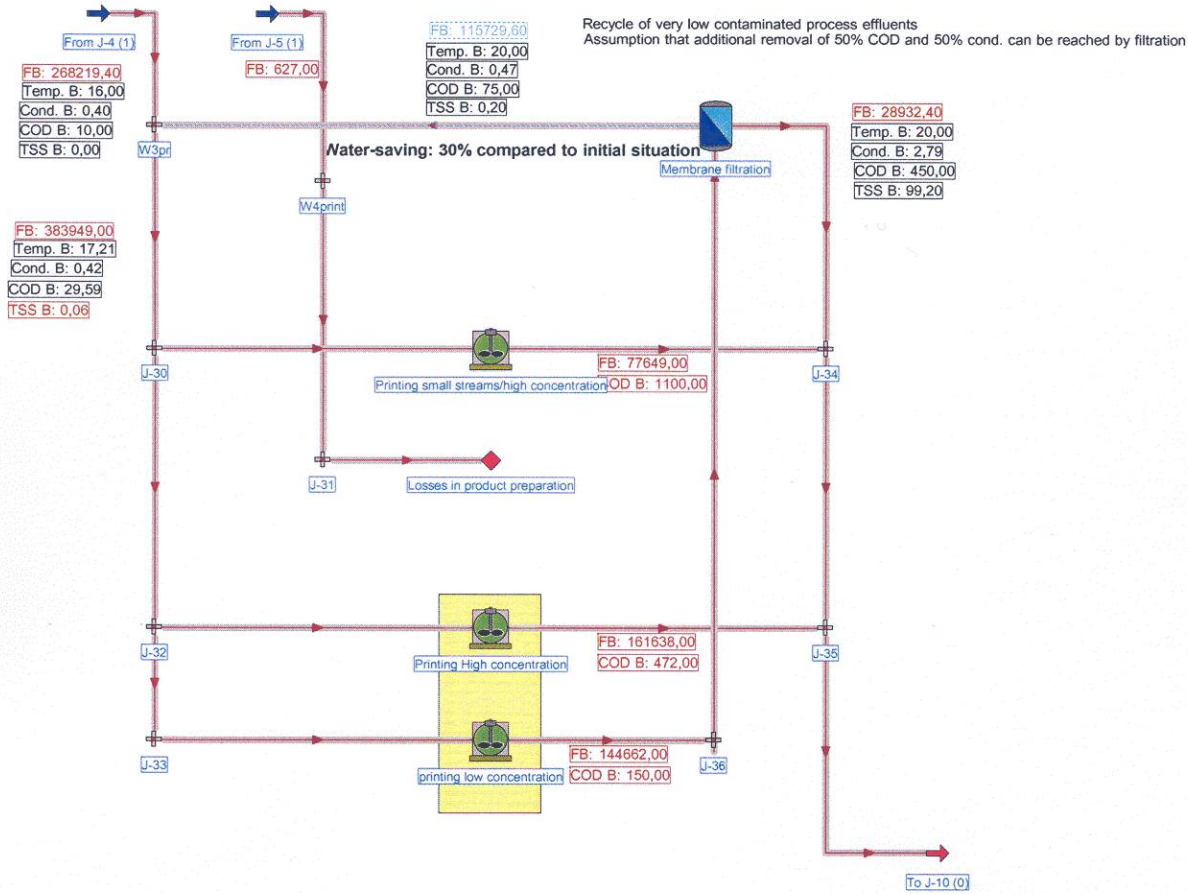

Company I15: Optimized - printing

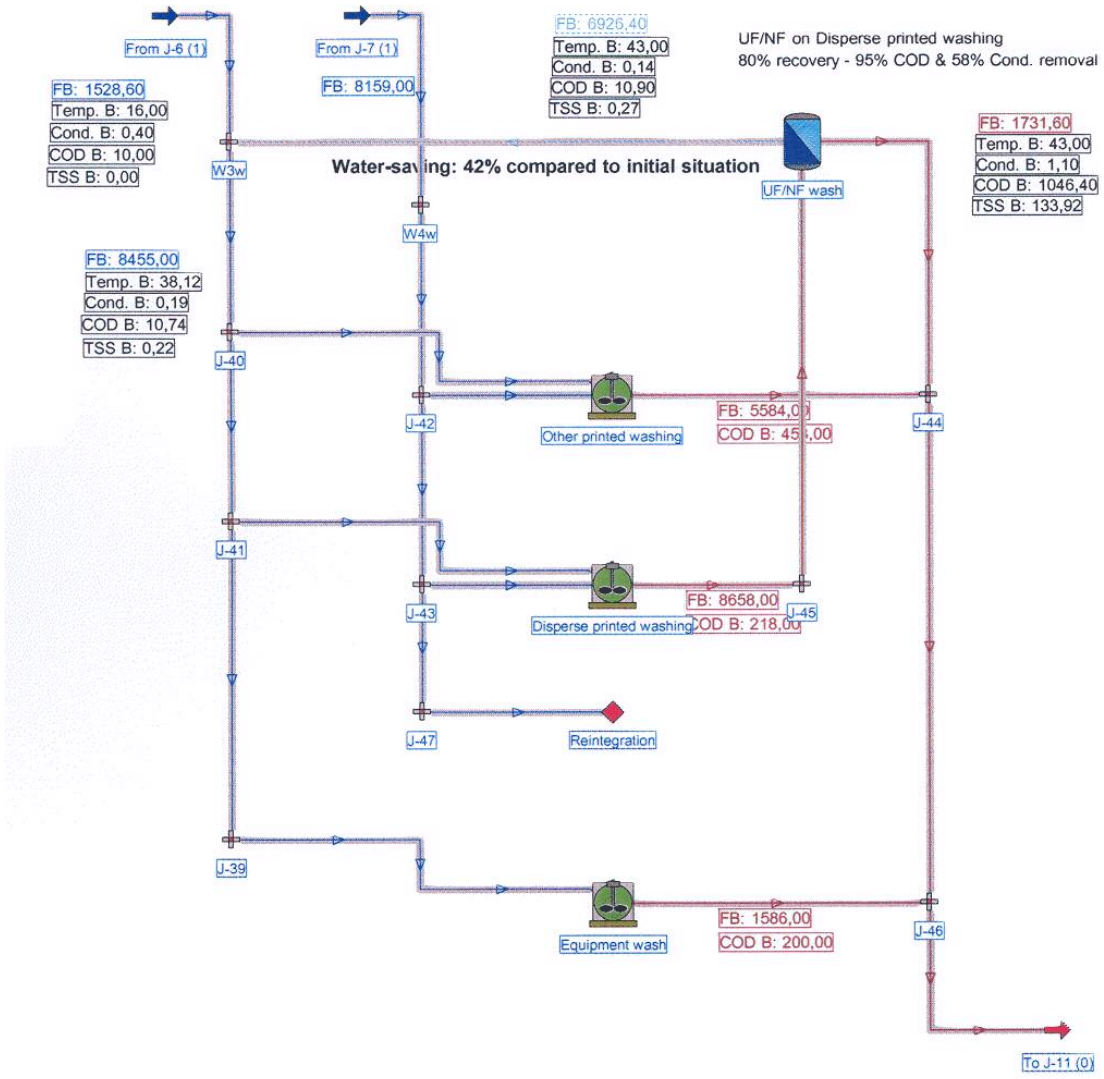

Company I15: Optimized - washing